

Weights

Operating weight	4905 kg
Additional weight for cab with HVAC	19 kg
Additional weight for long dipperstick	235 kg
Ground pressure with rubber tracks	26.90 kPa

Engine

Make / model	Kubota / V2403-M-D1-TE3B-BC-4
Fuel	Diesel
Number of cylinders	4
Displacement	2433 cm ³
Maximum NET power (ISO 9249)	35.4 kW
Maximum NET torque (ISO 9249)	179.5 Nm

Performance

Digging force, dipperstick (ISO 6015)	28700 N
Digging force, long dipperstick (ISO 6015)	26100 N
Digging force, bucket (ISO 6015)	42000 N
Drawbar pull	52343 N
Travel speed, low range	3.1 km/h
Travel speed, high range	5.0 km/h

Hydraulic System

Pump type	Single outlet variable displacement, load sensing torque limited pump
Piston pump capacity	138.50 L/min
Auxiliary flow	75.70 L/min
Auxiliary relief	210.0 bar

Slew System

Boom swing, left	75.0°
Boom swing, right	50.0°
Slew rate	9.0 RPM

Fluid Capacities

Cooling system	8.30 L
Engine lubrication plus oil filter	7.10 L
Fuel reservoir	79.90 L
Hydraulic reservoir	15.10 L
Hydraulic system	54.90 L

Environmental

Noise level LpA(EU Directive 2006/42/EC)	81 dB(A)
Noise level LWA(EU Directive 2000/14/EC)	96 dB(A)
Whole body vibration (ISO 2631-1)	0.16 ms ⁻²
Hand-arm vibration (ISO 5349-1)	0.43 ms ⁻²

Standard Features

1960 mm dozer blade	Fingertip auxiliary hydraulic control
400 mm rubber track	Horn
Auto idle	Full fuel warning alarm
Auto shift travel	Hydraulic joystick controls
Auxiliary hydraulics with Quick Couplers	Machine IQ (telematic)
Selectable auxiliary hydraulic flow	Retractable seat belt
Blade float feature	Suspension seat with high back
Clamp ready	TOPS/ROPS* canopy ¹
Control console locks	Two-speed travel
Cupholder	Work lights
Engine/hydraulic monitor with shutdown	Warranty: 12 months, 2000 hours (whichever occurs first)

1. Roll Over Protective Structure (ROPS) – Meets requirements of ISO 3471. Tip Over Protective Structure (TOPS) – Meets requirements of ISO 12117.

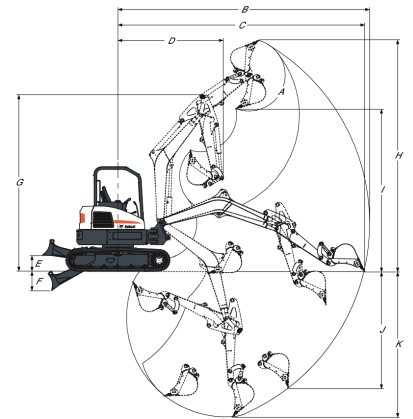
Working Range

(A)	185.0°	(G)	4269.0 mm
(B)	6062.0 mm	(H)	5595.0 mm
(B)	6441.0 mm	(H*)	5850.0 mm
(C)	5939.0 mm	(I)	3924.0 mm
(C*)	6333.0 mm	(I*)	4179.0 mm
(D)	2541.0 mm	(J)	2815.0 mm
(D*)	2639.0 mm	(J)	3199.0 mm
(E)	385.0 mm	(K)	3524.0 mm
(F)	465.0 mm	(K*)	3923.0 mm

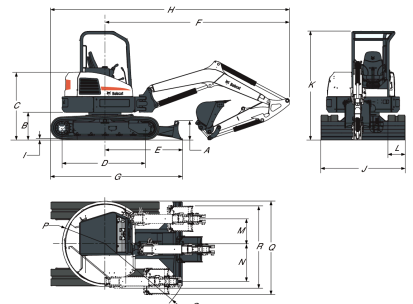
Dimensions

(A)	446.0 mm	(J)	1960.0 mm
(B)	640.0 mm	(K)	2541.0 mm
(C)	1575.0 mm	(L)	400.0 mm
(D)	1998.0 mm	(M)	586.0 mm
(E)	1788.0 mm	(N)	675.0 mm
(F)	4294.0 mm	(O)	2027.0 mm
(G)	3049.0 mm	(P)	997.0 mm
(H)	5555.0 mm	(P*)	1071.0 mm
(H*)	5563.0 mm	(Q)	2074.0 mm
(I)	25.0 mm	(R)	1874.0 mm

Options

Air conditioning	Travel motion alarm
Long dipperstick	Steel tracks
2nd Auxiliary hydraulics	Beacon kit
Dlx textile suspension seat	Left and right mirror
Boom safety valve with overload warning	Additional work light kit
Boom & arm safety valves with overload warning	Rubber bolt-on pads for steel tracks
AM/FM stereo radio	Special applications kit
FOGS kit (Overhead guard)	Hydraulic coupler lines
Lifting chain kit	